

SINAX D-15 Sinergo industrial robot
mono & bi component dispensing

- “top class” design & construction
- high performance PLC NC PC motion controller
- recirculating balls guides and screws.
- very high speed and precision movements.
- **mono or bi-component** dispensing .
- **A:B ratio** setting by software.
- **V1 V2 volumetric pumps** coupled to **brushless**.
- **V1 V2 pumps + XYZ interpolated** movement.
- drop free, easy maintenance, stainless steel valve.
- high repeatability, not depending from viscosity.
- automatic **pumping units**: from tanks to robot.
- custom versions available.
- options: remote control, traceability, dynamic mixer, machine vision, multi-nozzles dosing, ...
- accurate risk assessment and safety protections.
- CE compliant.
- EPA compliant. 



Made in Italy

SINAX D-15 industrial mono & bi component volumetric dispensing robot

- “desktop” or “floor version” (detachable stand). option
- piece loading by operator, on tray.
- rotating servo table version.
- fully automatic versions: pallet line or smema line.

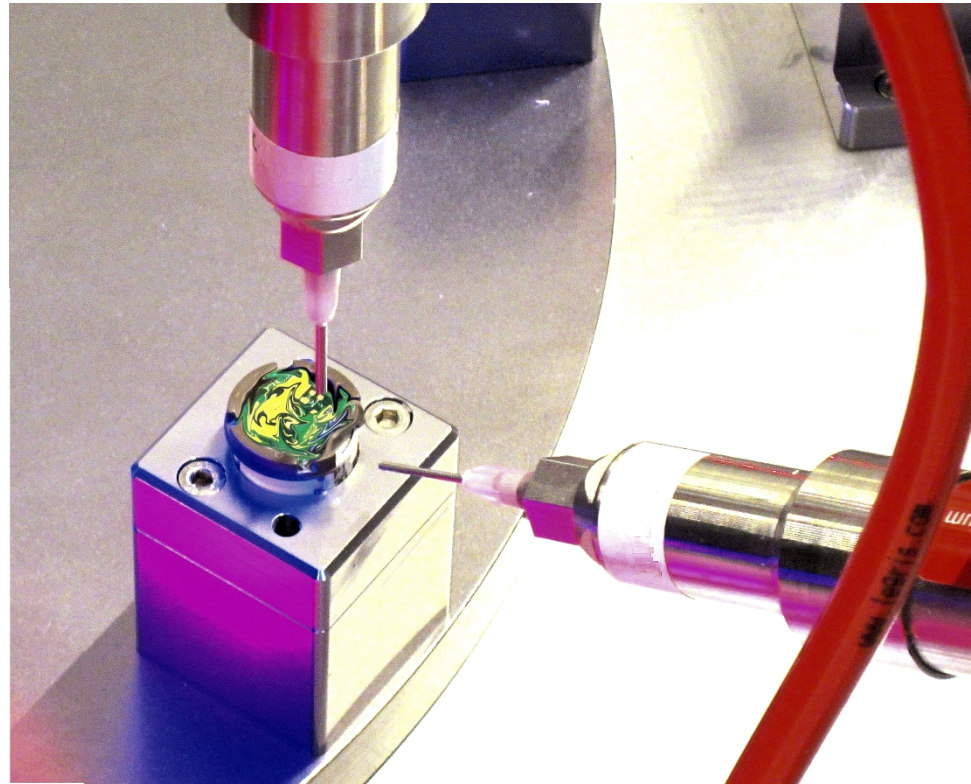

- 330x350xH150 mm effective working area.

Integrated control of pumping units for component A and B

OPTIONS:

- machine vision for the piece recognition
 - process study and optimization
 - dedicated tooling design and supply.
- barcode or datamatrix reader integration
 - Larger working area version

SINAX D-15 industrial **mono & bi component volumetric dispensing** robot

- 15" touch panel PC Human Machine Interface.
- Multilanguage display (language file loading)
- Five levels password access.
- Infinite numbers of working programs.
- Many functions available: single dot, contour, optimized circle and corner dispensing, ...
- Indexed fixtures and/or pallet recognition.
- Over internet remote diagnostic & managing
- Management of pallet stopper, lifter, interface to external line PLC, ...
- UV curing set integration
- Pump units integration

"UV" set
Ultraviolet light
fast curing glue.

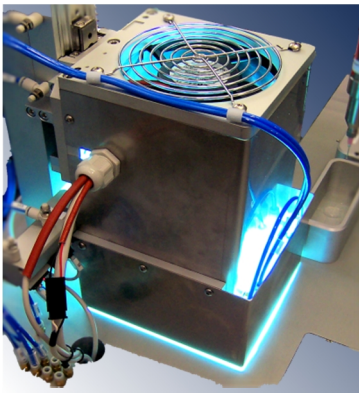

PUMP units
to feed fluids A & B
to the robot

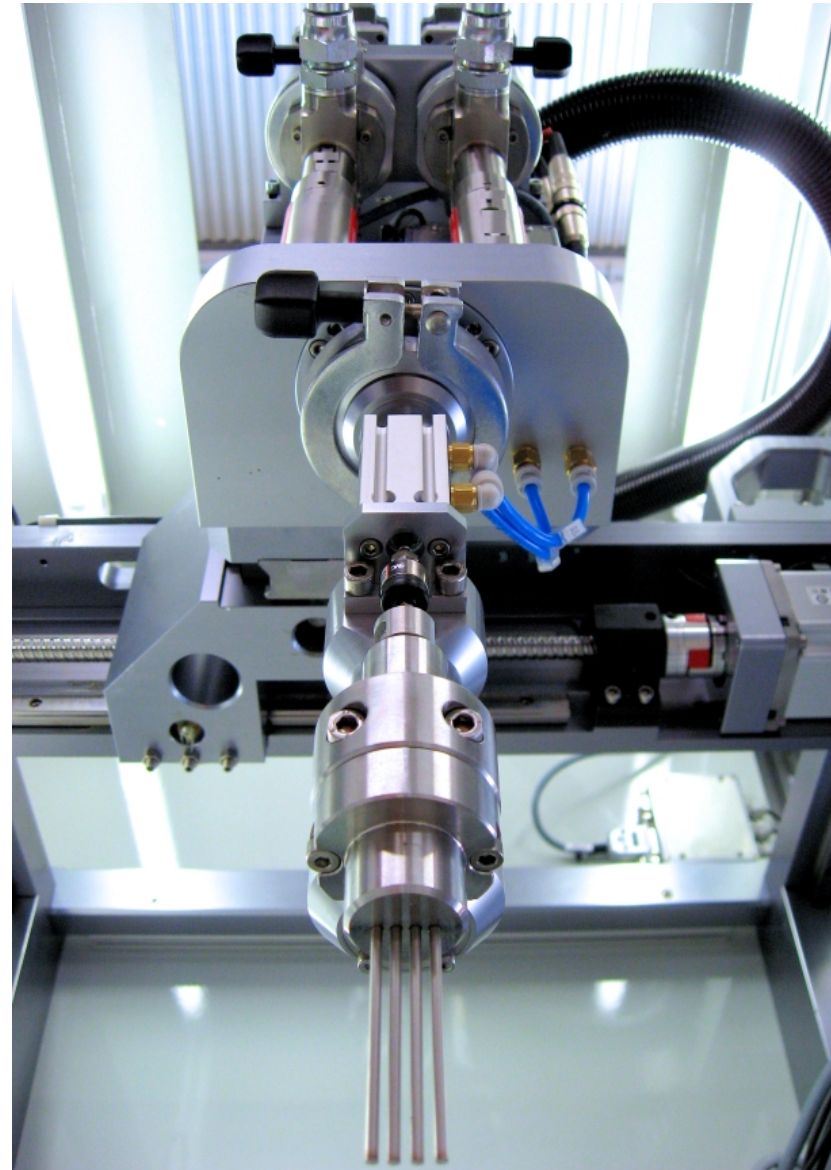

SINAX D-15 industrial mono & bi component volumetric dispensing robot



since 1991

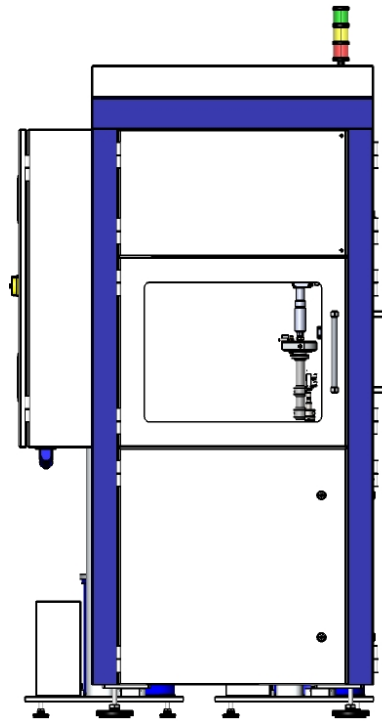
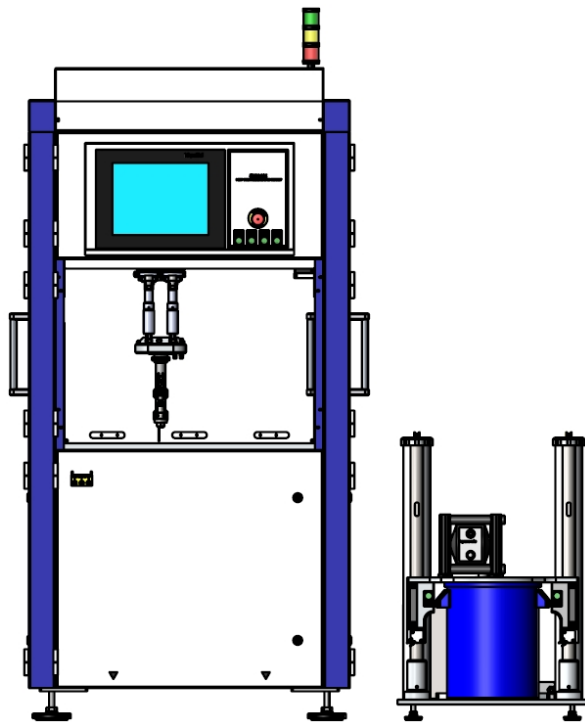

Width 1150 mm max
 Depth 1200 mm max
 Height 2100 mm max + lights
 Weight ~450 Kgs max

← Detachable floor stand (option)

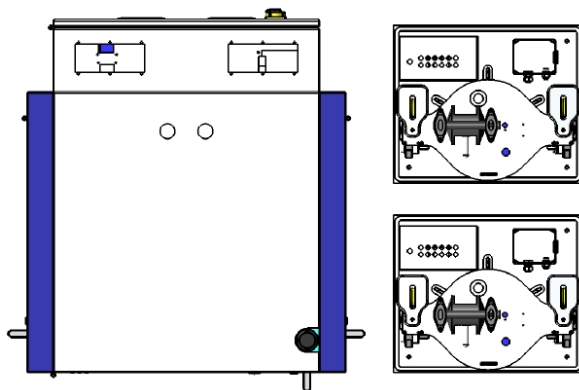

main supply: 1x230 Vac 50-60 Hz CEE17 16A socket
 power consumption: max 16 A
 compressed air 6Kg/cm² connection
 LAN & USB socket
 ESD bracelet point socket
 Sinergo software license
 panel PC Windows 7 license

